

**SERVICE REPAIR**

**MANUAL**

Hyster C453 (W20ZR, W30ZR, W40Z) Forklift  
Service Repair Manual

***HYSTER***

# PERIODIC MAINTENANCE

**W30-40ZA [B453, C453];  
W20-30ZR [B455, C455];  
W25-30-40ZC [B454, C454]**

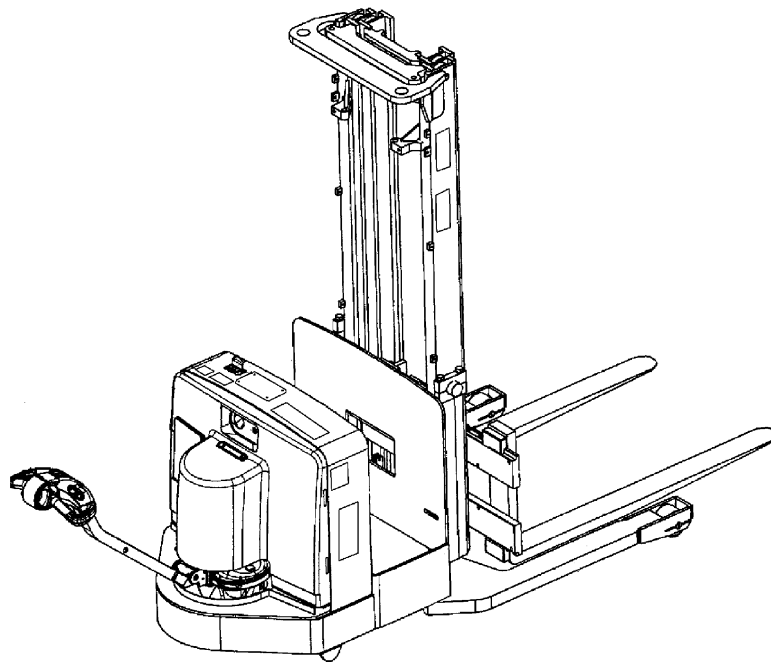

# ***HYSTER***

# SAFETY PRECAUTIONS

## MAINTENANCE AND REPAIR

- The Service Manuals are updated on a regular basis, but may not reflect recent design changes to the product. Updated technical service information may be available from your local authorized Hyster® dealer. Service Manuals provide general guidelines for maintenance and service and are intended for use by trained and experienced technicians. Failure to properly maintain equipment or to follow instructions contained in the Service Manual could result in damage to the products, personal injury, property damage or death.
- When lifting parts or assemblies, make sure all slings, chains, or cables are correctly fastened, and that the load being lifted is balanced. Make sure the crane, cables, and chains have the capacity to support the weight of the load.
- Do not lift heavy parts by hand, use a lifting mechanism.
- Wear safety glasses.
- DISCONNECT THE BATTERY CONNECTOR before doing any maintenance or repair on electric lift trucks. Disconnect the battery ground cable on internal combustion lift trucks.
- Always use correct blocks to prevent the unit from rolling or falling. See HOW TO PUT THE LIFT TRUCK ON BLOCKS in the Operating Manual or the Periodic Maintenance section.
- Keep the unit clean and the working area clean and orderly.
- Use the correct tools for the job.
- Keep the tools clean and in good condition.
- Always use HYSTER APPROVED parts when making repairs. Replacement parts must meet or exceed the specifications of the original equipment manufacturer.
- Make sure all nuts, bolts, snap rings, and other fastening devices are removed before using force to remove parts.
- Always fasten a DO NOT OPERATE tag to the controls of the unit when making repairs, or if the unit needs repairs.
- Be sure to follow the WARNING and CAUTION notes in the instructions.
- Gasoline, Liquid Petroleum Gas (LPG), Compressed Natural Gas (CNG), and Diesel fuel are flammable. Be sure to follow the necessary safety precautions when handling these fuels and when working on these fuel systems.
- Batteries generate flammable gas when they are being charged. Keep fire and sparks away from the area. Make sure the area is well ventilated.

**NOTE:** The following symbols and words indicate safety information in this manual:



### **WARNING**

Indicates a hazardous situation which, if not avoided, could result in death or serious injury.



### **CAUTION**

Indicates a hazardous situation which, if not avoided, could result in minor or moderate injury and property damage.

On the lift truck, the **WARNING** symbol and word are on orange background. The **CAUTION** symbol and word are on yellow background.

## TABLE OF CONTENTS

General .....	1
How to Move a Disabled Lift Truck .....	1
How to Tow a Lift Truck .....	2
How to Put The Lift Truck on Blocks .....	3
How to Raise the Drive/Steer Tire .....	3
How to Raise the Load Wheels .....	5
How to Raise the Load Wheels (W25-30-40ZC).....	5
Safety Procedures When Working Near Mast .....	6
Maintenance Schedule .....	8
Maintenance Procedures Every 8 Hours or Daily .....	14
Checks Before Operation .....	14
How to Make Checks With Key Switch OFF .....	14
Safety Labels .....	14
Battery .....	15
Brake .....	16
Tires and Wheels .....	16
Mast, Forks, and Lift Chains .....	16
Reach Mechanism (W20/30ZR).....	18
Control Handle .....	19
Hydraulic System .....	19
How to Make Checks With Key Switch ON .....	19
Check for Leaks in Lift System .....	19
Control Buttons.....	20
Direction/Speed Control and Switches .....	20
Gauges, Horn, Fuses .....	21
Maintenance Procedures Every 350 Hours or Every 2 Months .....	22
Fittings Lubrication .....	22
All Walkie High Lift Trucks .....	23
W30/40ZA and W25/30/40ZR.....	23
W20/30ZR.....	23
Integral Sideshift .....	23
Hang On Sideshift .....	23
Load Wheel Bearings () W30/40ZA and W20/30ZR.....	23
Other Lubrication .....	23
Lift Chain Adjustments .....	23
Drive Wheel .....	25
Brake .....	25
Hydraulic System .....	25
Hydraulic Hoses and Fittings .....	26
Fluid Level .....	26
Hydraulic Reservoir Breather .....	26
Master Drive Unit .....	26
Check Oil Level .....	26
Traction and Pump Motor Brushes .....	26
Contactor .....	28
Maintenance Procedures Every 2000 Hours or Yearly .....	29
Hydraulic Oil Change .....	29
Load Wheel Bearings () W25/30/40ZC.....	31
Remove .....	31
Install .....	33

## TABLE OF CONTENTS (Continued)

Master Drive Unit .....	33
Drive Unit Gear Oil .....	33
Welding Repairs .....	33
General Repairs .....	34
Load Wheels (W30-40ZA and W20-30ZR).....	34
Remove .....	34
Install .....	36
Lift Cylinder Leak Test .....	36
Battery Maintenance .....	37
How to Charge the Battery .....	37
Normal Charge .....	37
Equalizing Charge .....	38
How to Change the Battery .....	38
Standard Battery Spacer Adjustment .....	38
Changing the Battery With an Overhead Crane .....	39
Remove .....	39
Install .....	39
Changing Battery With Rollers .....	40
Remove .....	42
Install .....	42

This section is for the following models:

(W30-40ZA) [B453, C453];  
(W20-30ZR) [B455, C455];  
(W25-30-40ZC) [B454, C454]

**Thanks very much for your reading,  
Want to get more information,  
Please click here, Then get the complete  
manual**

**JustClickHere** 

**NOTE:**

**If there is no response to click on the link above,  
please download the PDF document first, and then  
click on it.**

**Have any questions please write to me:  
[admin@servicemanualperfect.com](mailto:admin@servicemanualperfect.com)**

## General

This section contains a Maintenance Schedule and the instructions for maintenance and inspection.

The Maintenance Schedule has time intervals for inspection, lubrication, and periodic maintenance. The time intervals are based on normal operation. Normal operation is considered to be one 8-hour shift per day in a relatively clean environment on an improved surface. Multiple shifts, dirty operating conditions, etc., will require a reduction in the recommended time periods in the Maintenance Schedule.

**NOTE:** The front end of the lift truck is the control handle end. Forward travel is movement with the forks trailing. Rear travel is movement in the direction of the forks.



### WARNING

**DO NOT** make repairs or adjustments unless specifically authorized to do so. Repairs and adjustments must be performed by trained service technicians.

Repairs and adjustments that are not correct can create dangerous operating conditions.

**DO NOT** operate a lift truck that needs repairs. Report the need for repairs to your supervisor immediately. If repair is necessary, place a **DO NOT OPERATE** tag on the control handle and remove the key from the key switch.

Some users have service personnel and facilities to perform the tasks listed in the Maintenance Schedule. Service Manuals are available from your Hyster® lift truck dealer to help users who do their own repairs.

Your Hyster lift truck dealer has the trained personnel and equipment to do a complete program of inspection, lubrication, and maintenance. This complete program will help your lift truck operate better over a longer period of time.

## HOW TO MOVE A DISABLED LIFT TRUCK



### WARNING

Use extra care when moving a lift truck during the following conditions:

- Brake does not operate correctly
- Steering does not operate correctly
- Tire is damaged
- Traction conditions are bad

If there is no power, the drive wheel will not turn freely. Poor traction can cause the disabled lift truck or towing vehicle to slide. Grades will require additional brake force to stop the lift truck.

Never carry a disabled lift truck unless the lift truck **MUST** be moved and cannot be towed. The lift truck used to lift the disabled lift truck **MUST** have a rated capacity equal to or greater than the weight of the disabled lift truck. The capacity must be for a load center equal to half the width of the disabled lift truck. See the nameplate on the disabled lift truck for the approximate total weight. The forks must extend the full width of the disabled lift truck. Put the weight of the disabled lift truck at the center of the forks. Be careful not to damage the underside of the disabled lift truck. Tilt the mast back and travel slowly.

Lift trucks are not normally towed. If the traction system will not operate, make repairs at the location if possible. If the lift truck must be towed, tow in the direction of the control handle, forks trailing.

## How to Tow a Lift Truck

### WARNING

Prior to releasing the electric brake, make sure the lift truck is blocked correctly to prevent movement causing damage to personnel or equipment.

Stay clear of the tow chain, towing vehicle, and lift truck during the towing operation to prevent injury.

Make sure no one except the driver is near the lift trucks during towing. Both the tow truck and the disabled truck can cause an injury during towing.

### CAUTION

Never tow the lift truck faster than the speed of a person walking. Steering can be difficult, and motor damage can occur at higher speeds. Always tow smoothly without sudden starts. Never tow the lift truck using the control handle.

Until repairs are complete keep a tag on the control handle stating **DO NOT OPERATE**. Remove the key.

In order to move a disabled lift truck, the electric brake must be released. A jumper is provided in the wiring harness to supply battery voltage directly to the electric brake to release it.

1. Block the lift truck to prevent it from moving.
2. Turn the key switch to the OFF position.
3. Disconnect and separate the battery connectors.
4. Remove drive unit cover to allow access to wiring harness.
5. Locate Brake Harness and Brake Override Circuit Connector (three 4-pin connectors in the wiring harness near the brake). See Figure 1.

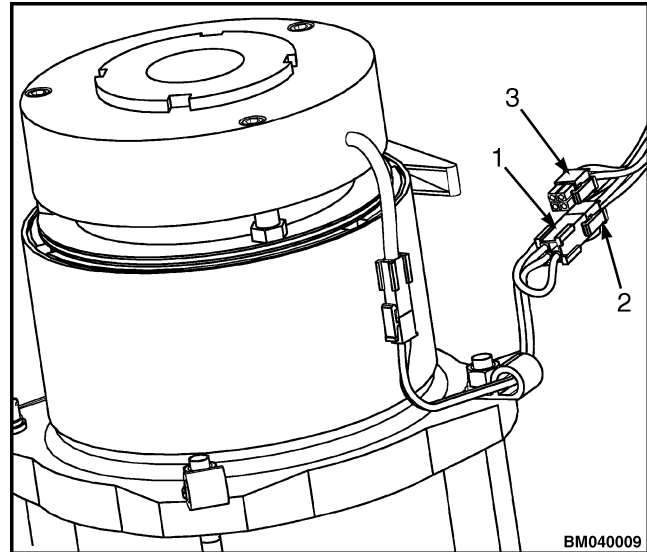

1. BRAKE HARNESS
2. BRAKE OVERRIDE CIRCUIT CONNECTOR
3. NORMAL OPERATION CONNECTOR

*Figure 1. Brake Override Connector*

6. Unplug the Brake Harness Connector from the Normal Operation Connector. This will disable the lift truck MDU.
7. Plug the male side of the Brake Override Circuit Connector into the female side of the Brake Harness.
8. Fasten the chain to the lift truck. Make sure the tow chain has the capacity to tow the weight. Carefully fasten the tow chain completely around the motor and battery compartments on top of the forks. The chain must not cause damage to either lift truck.
9. Steer the lift truck with the control handle while it is being towed. Use one hand and walk to one side of the truck. **DO NOT** get between the towing vehicle and the lift truck.



10. Connect the battery connectors to disengage the brake.
11. Tow the lift truck slowly.
12. If another lift truck that has the drive wheels near the forks is used to tow the disabled lift truck, that lift truck must have weight added to the forks. The total weight of the lift truck and load must be equal to or greater than the weight of the disabled lift truck. Install a load of approximately half the maximum capacity on the forks of the lift truck that is used for towing. This load will increase the traction of the lift truck. Keep the load on the forks lowered as much as possible.

If the lift truck used for towing has a master drive unit (MDU) or drive unit similar to this lift truck, DO NOT add weight to the forks. Additional weight on the forks may DECREASE the traction of the drive wheel(s). Make sure that the lift truck has a total weight equal to or greater than the weight of the disabled lift truck.



### **WARNING**

**Always unplug the Brake Override Circuit and connect the Brake Harness prior to operating the lift truck.**

13. Make sure the Brake Override Circuit is disconnected from the Brake Harness prior to operating the lift truck.

## **HOW TO PUT THE LIFT TRUCK ON BLOCKS**



### **WARNING**

**DO NOT put the lift truck on blocks if the surface is not solid, even, and level. Make sure that any blocks used to support the lift truck are solid, one-piece units. Put a block in front and back of the tires touching the ground to prevent movement of the lift truck.**

**DO NOT raise the lift truck by attaching an overhead lifting device to areas that can be damaged. Some of these points are not designed to support the weight of the lift truck. The lift truck can be damaged or it can fall, causing serious injury. Attach the chain or sling to a support structure of the lift truck frame.**

DO NOT make repairs or adjustments unless specifically authorized to do so. Repairs and adjustments must be performed by trained service technicians.

## **How to Raise the Drive/Steer Tire**

1. Put blocks on both the front and back sides of the load wheels to prevent movement of the lift truck. Refer to Figure 3 and Figure 4.

Use a special low-clearance hydraulic jack, crane, or another lift truck to raise the drive tire. Make sure that the jack, crane, or other lift truck has the correct capacity rating. The capacity must equal at least two-thirds (2/3) the weight of the lift truck, including the battery. See the nameplate for the lift truck weight.

**NOTE:** Perform Step 2 for lift truck models (W25-30-40ZC).

2. Raise the lift truck enough to suspend the drive tire.



### **WARNING**

**DO NOT lift both ends at once.**

**NOTE:** Perform Step 3 for lift truck models (W30-40ZA and W20-30ZR).

3. To raise drive end of lift truck, hook a lift strap under the bumper on both sides or hook the lift strap under the drive frame cowl. Raise the lift truck only enough to suspend the drive tire. See Figure 2.

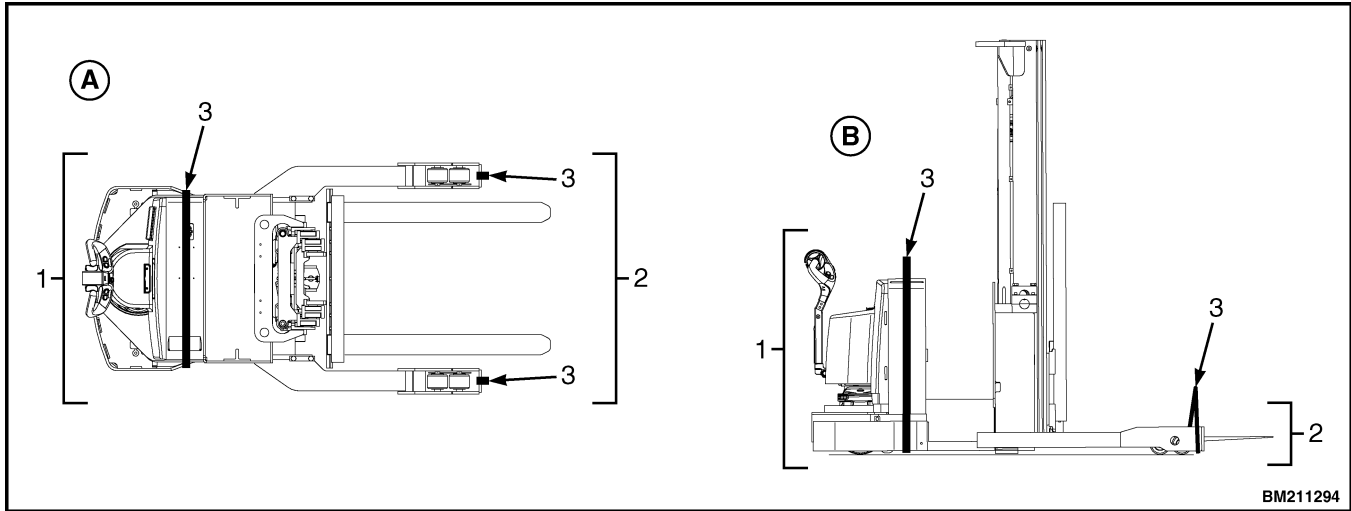

A. TOP VIEW

B. LEFT VIEW

- 1. DRIVE END
- 2. FORK END

- 3. STRAP

**Figure 2. Lifting Points (W30-40ZA, W20-30ZR)**

- 4. Install additional blocks under the frame near the drive tire. See Figure 3 and Figure 4.

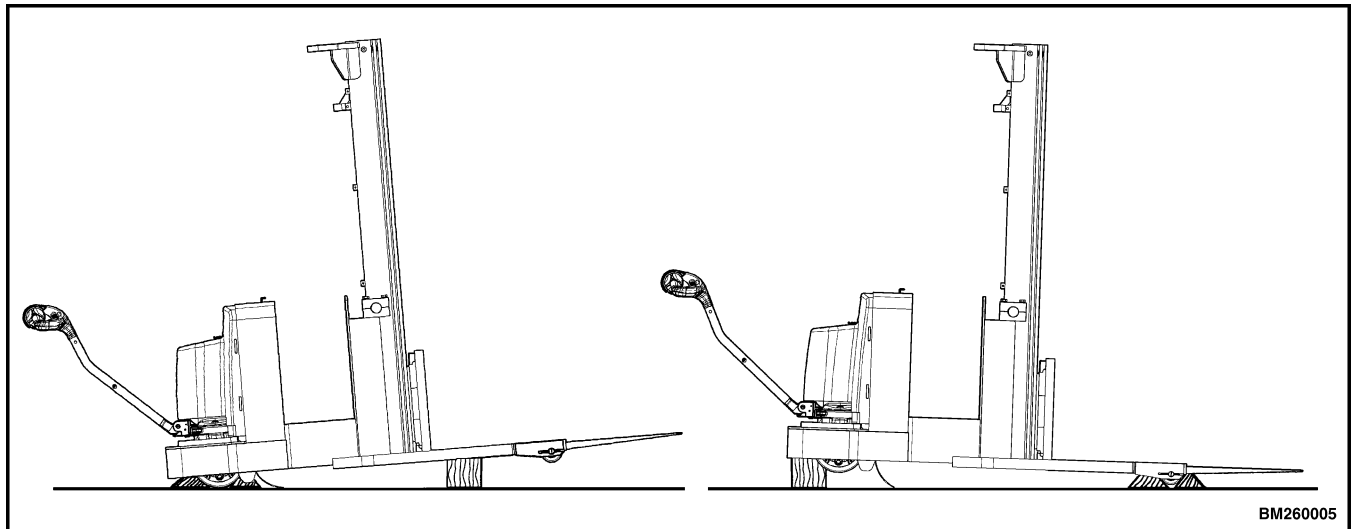

**Figure 3. Putting Lift Truck on Blocks (W30-40ZA and W20-30ZR)**

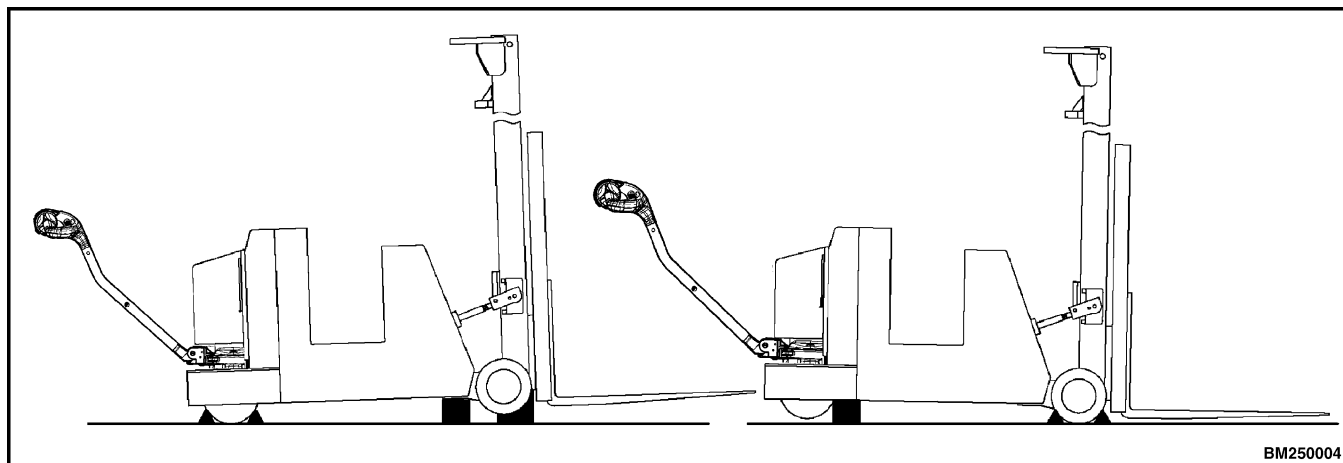

**Figure 4. Putting Lift Truck on Blocks (W25-30-40ZC)**

### How to Raise the Load Wheels (W30-40ZA and W20-30ZR)



#### **WARNING**

Never raise the base arms any higher than necessary to change the load wheels. Always raise both base arms at the same time. Raising the base arms too high can make the lift truck tip over and cause damage or possible injury.

1. Put blocks on both the front and back sides of the drive tire to prevent movement of the lift truck. Refer to Figure 3.
2. Use an overhead lifting device and web sling under the base arms at the mast to raise the load wheels. Another lift truck can also be used to raise the base arms. Make sure the overhead lifting device and web sling or other lift truck has a capacity of at least two-thirds (2/3) the total weight of the lift truck including the battery. See the nameplate for the lift truck weight.



#### **WARNING**

**DO NOT lift both ends at once.**

3. To raise the fork end of the lift truck, hook a lift strap through each load wheel opening in the top of each fork and lift together. See Figure 2.

Raise the outriggers only enough to suspend the wheels. Install blocks under the outriggers at the rear of the wheels to support the lift truck. See Figure 3.

### How to Raise the Load Wheels (W25-30-40ZC)

For the following instructions, refer to Figure 4.

1. Put the mast in the vertical position. Put a block under each outer upright.
2. Tilt the mast fully forward until the load wheels are raised from the floor.
3. Put blocks under the frame behind the load wheels.
4. Put blocks on both sides (front and back) of the drive tire to prevent movement of the lift truck.
5. If the hydraulic system will not operate, use a hydraulic jack under the side of the frame near the front. Make sure the jack has a capacity equal to at least two-thirds (2/3) the weight of the lift truck including the battery. See the nameplate for the lift truck weight.

## Safety Procedures When Working Near Mast

The following procedures must be used when inspecting or working near the mast. Additional precautions and procedures can be required when repairing or removing the mast.



### WARNING

**Mast parts are heavy and can move. Distances between parts are small. Serious injury or death can result if part of the body is hit by parts of the mast or the carriage.**

- **Never put any part of the body into or under the mast or carriage unless all parts are completely lowered or a safety chain is installed. Also, make sure the power is off and the key is removed. Put a DO NOT OPERATE tag in the operator's compartment. Disconnect the battery and put a tag or lock on the battery connector.**
- **Be careful of the forks. When the mast is raised, the forks can be at a height to cause an injury.**
- **DO NOT climb on the mast or lift truck at any time. Use a ladder or personnel lift to work on the mast.**
- **DO NOT use blocks to support the mast weldments nor to restrain their movement.**
- **Mast repairs require disassembly and removal of parts and can require removal of the mast or carriage. Follow the repair procedures in the correct Service Manual section.**

WHEN WORKING NEAR THE MAST ALWAYS:

1. Lower mast and carriage completely. Make sure all parts of mast that move are fully lowered. Push lift/lower control button and make sure there is no movement in mast.

OR

2. If parts of the mast must be in raised position, install a safety chain to restrain moving parts of mast. Connect moving parts to a part that does not move. Follow these procedures:
  - a. Raise mast to align bottom or middle cross-member of inner weldment with top of outer weldment. On the two-stage mast, the moving part is the inner weldment. On the three-stage mast, it is both the inner and intermediate weldments. See Figure 5.
  - b. Install a safety chain (3/8-in. minimum) with a hook around lower crossmember of inner weldment and top of outer weldment. Put hook on back side of mast. Make sure hook is completely engaged with a link in the chain. Make sure safety chain does not touch lift chains or chain sheaves, tubes, hoses, fittings, or other parts on mast.
  - c. Lower mast until there is tension in safety chain and free-lift cylinder (full free-lift masts only) is completely retracted. Move the key to the OFF position and remove the key from the key switch. Put a DO NOT OPERATE tag in the operator's compartment. Disconnect the battery and put a tag or lock on the battery connector. Install a DO NOT REMOVE tag on safety chain(s).

**NOTE:** MAST OPERATOR GUARD MUST BE REMOVED TO INSTALL SAFETY CHAIN. REMOVE SAFETY CHAIN AND INSTALL THE GUARD AFTER REPAIRS ARE COMPLETE.

**Legend for Figure 5**

- A.** TWO-STAGE MAST
- B.** THREE-STAGE MAST
- 1. OUTER WELDMENT
- 2. INNER WELDMENT
- 3. INTERMEDIATE WELDMENT
- 4. HOOK
- 5. FREE-LIFT CYLINDER
- 6. CARRIAGE

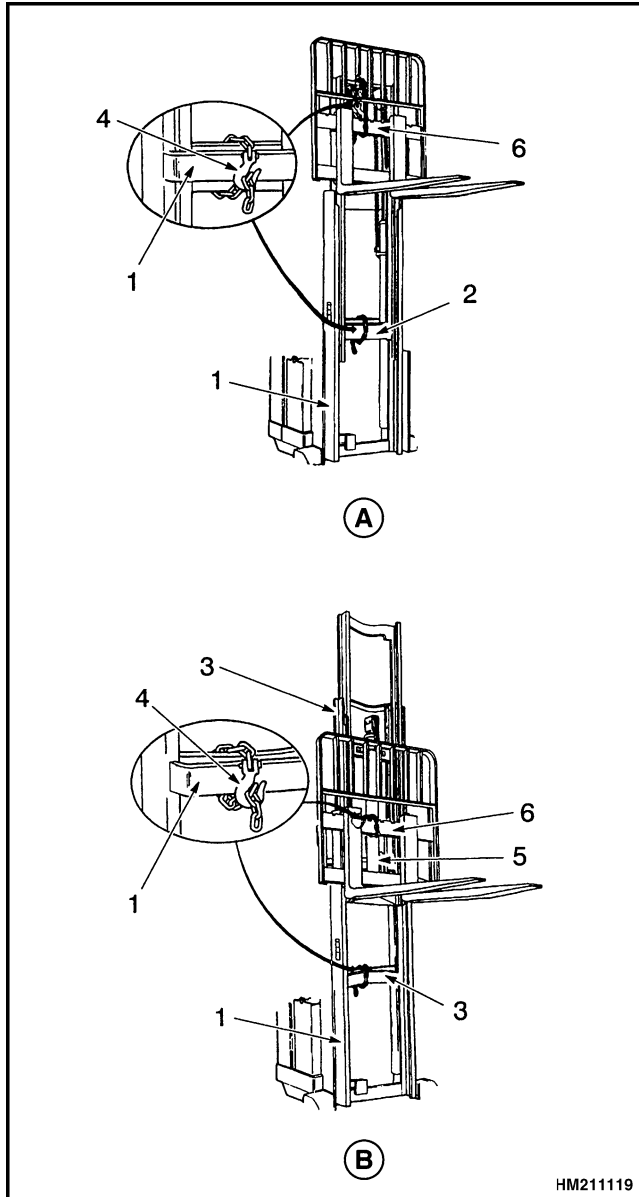

**Figure 5. Safety Chain the Mast**

## Maintenance Schedule

The Maintenance Schedule has time intervals for inspection, lubrication, and maintenance for your lift truck. The service intervals are given in both operating hours recorded on the lift truck hourmeter and in calendar time. The recommendation is to use the interval that comes first.



### **CAUTION**

**Trucks operating in non-standard or severe applications may require special optional environmental packages, additional maintenance procedures, more frequent service intervals, and/or special lubricants.**

The maintenance schedules are made according to the maximum service intervals for average conditions. Inspect and lubricate more frequently when operating in dirty or difficult conditions.

The approximate locations of the items indicated in Table 1 are shown in Figure 6, Figure 7, and Figure 8.

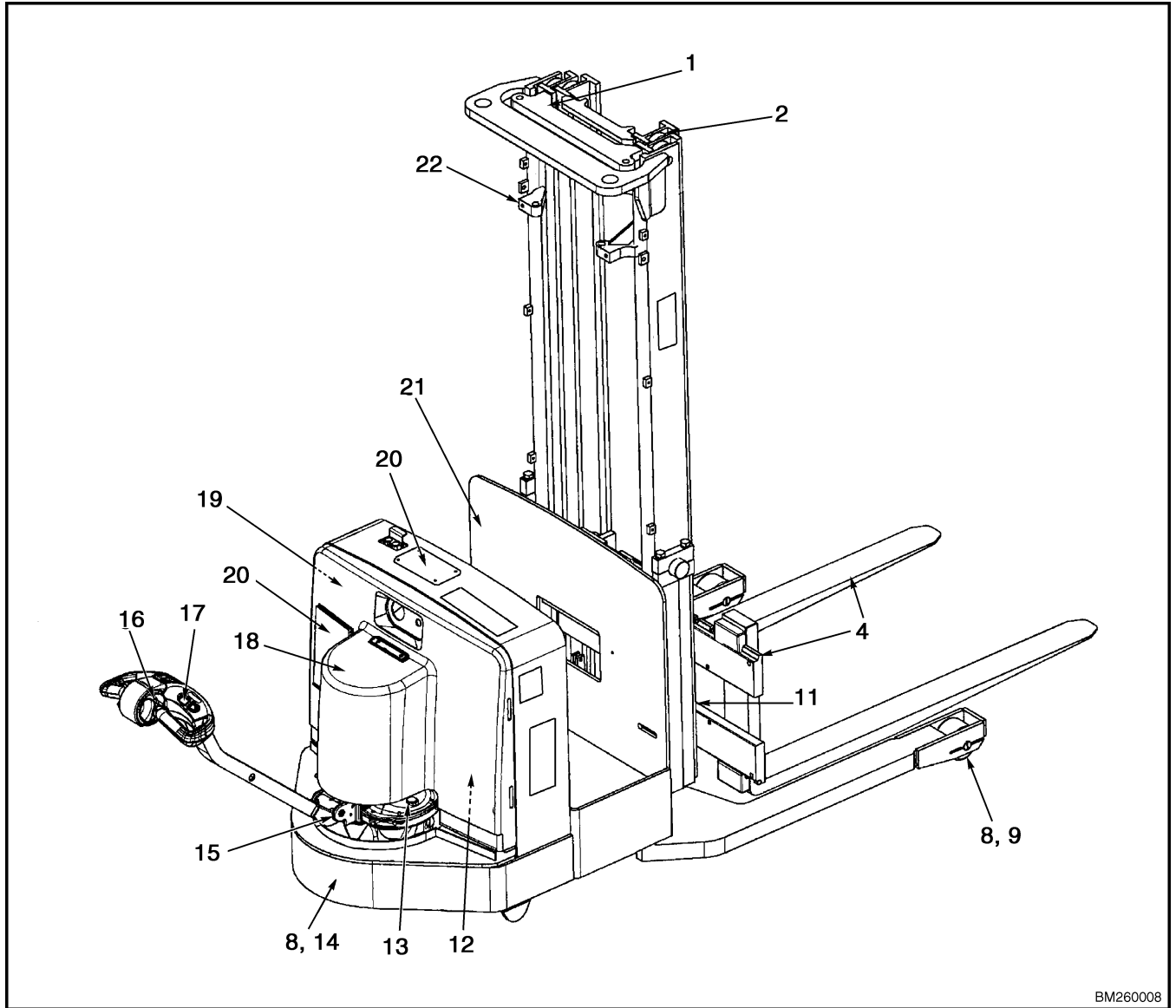

BM260008

Figure 6. Maintenance Points W30/40ZA

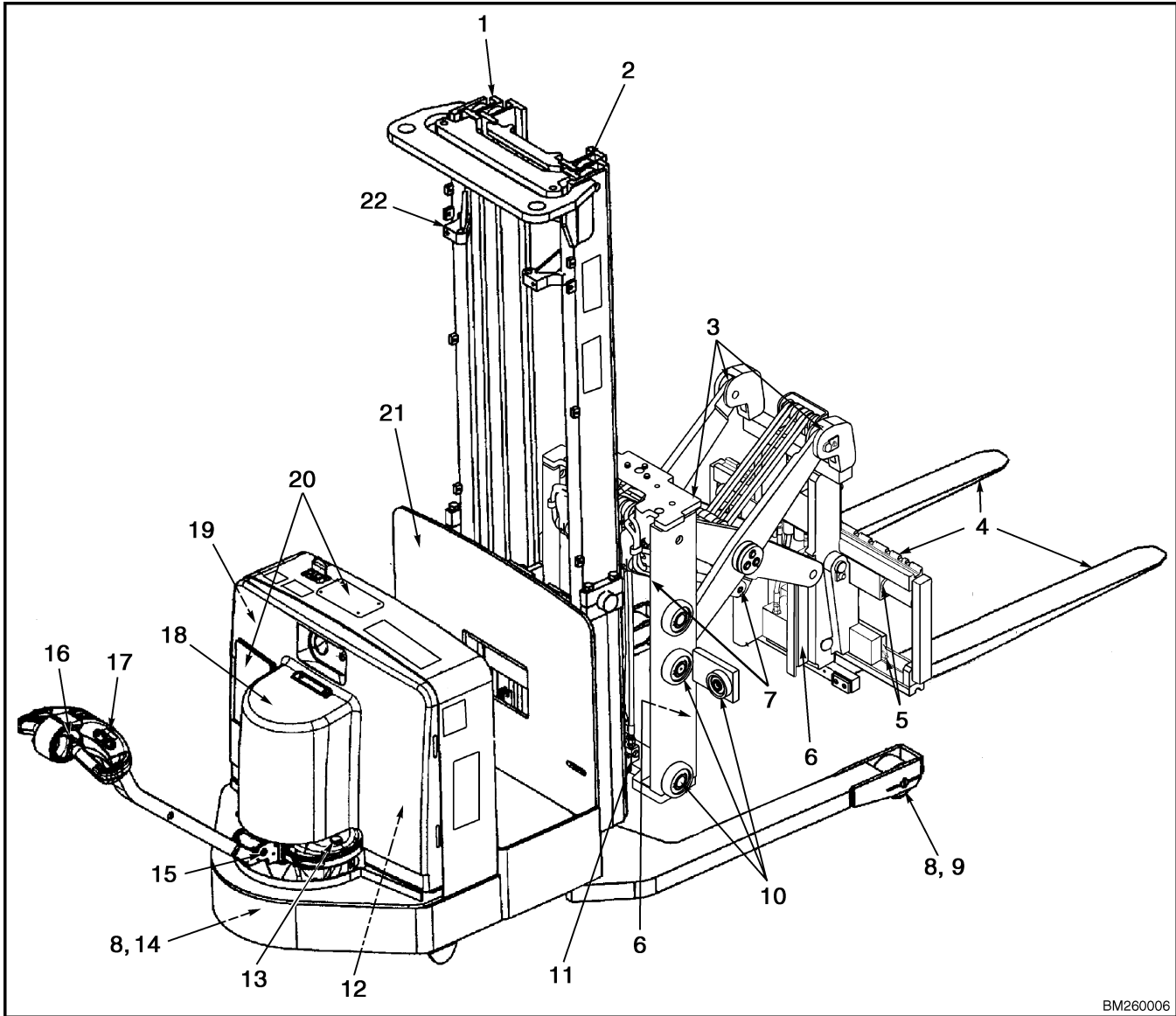

BM260006

Figure 7. Maintenance Points W20/30ZA



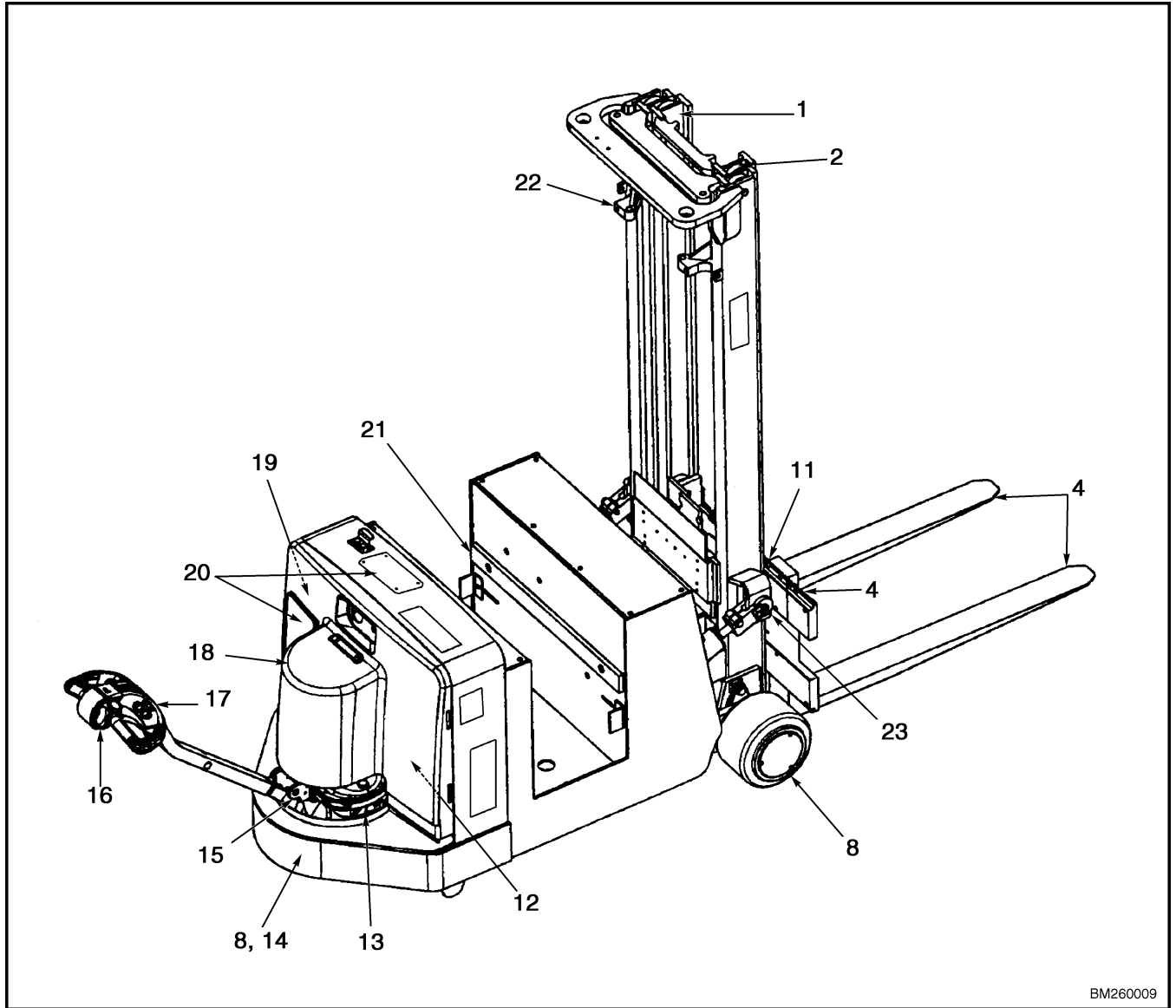

BM260009

Figure 8. Maintenance Points W25/30/40ZC

Table 1. Maintenance Schedule

Item		8 hr or 1 day	350 hr or 2 month	2000 hr or 1 year	Procedure or Quantity	Specification
No.	Description					
20	Safety Labels and Operating Manual	X			Replace if Necessary	See Parts Manual
21	Battery	X	X		Check Water Level	Equalization Charge <sup>3</sup>
18	Brake	X			Check Operation	
			X		Check Operation	Hold 10% grade with rated load
			X		Visually Inspect Brake	No Visible Damage
8	Drive Tire and Load Wheels	X			Check for Damage	Replace as Necessary
1	Mast	X			Check Condition	
	Channel Wear Surfaces		X and L		Clean and Lubricate	Multipurpose Grease <sup>1</sup>
	Wear Plugs		X and L		Clean and Lubricate	Multipurpose Grease <sup>1</sup>
22	Lift Chains <sup>4</sup>	X			Check Condition	SAE 20W or 30W Motor Oil
			X <sup>2</sup> and L		Clean, Check, and Lubricate	
4	Forks	X			Check Condition and Operation	Check With Fork Gauge
	Fork Guides and Lock Pins	X	L		Lubricate Pins and Sliding Surfaces	SAE 20W or 30W Motor Oil
6	Reach Assembly	X			Check Condition	
	Channel Wear Surfaces <sup>6</sup>		X and L		Clean and Lubricate	Multipurpose Grease <sup>1</sup>
12	Hydraulic System					
	Hydraulic Oil	X		C	Change Oil in MDU	Hydraulic Oil <sup>5</sup> To Correct Level
	Breather Cap			X	Clean or Replace	
	Hydraulic Oil Strainer			X	Clean or Replace	
	Hydraulic Hoses and Fittings	X			Visually Inspect	Replace as Required
		X		Check Hoses for Damage and Wear	Adjust or Replace as Required	
17	Lift/Lower Control	X			Check Operation	Smooth Operation, No Binding
	Extend/Retract Control	X			Check Operation	
	Sideshift Left/Right	X			Check Operation	
16	Directional/Speed Control	X			Check Operation	Smooth Operation, No Binding
19	Electrical					
	Circuits	X			Check Operation	Repair as required
	Motor Brushes		X		Check Condition	Replace as required

X=Check C=Change L=Lubricate

Table 1. Maintenance Schedule (Continued)

Item		8 hr or 1 day	350 hr or 2 month	2000 hr or 1 year	Procedure or Quantity	Specification
No.	Description					
	Gauges, Horn, and Fuses	X			Check Condition	Replace as required
15	Control Handle	X			Check Operation	Smooth, No Binding
	Pivot Shaft		L		1 Lube Fitting	Multipurpose Grease <sup>1</sup>
11	Articulating Chain Anchors (Carriage)		L		2 Lube Fittings	Multipurpose Grease <sup>1</sup>
10	Reach Carriage		X		Check Condition	
	Thrust Rollers		L	C	Clean and Lubricate 2 Lube Fittings	Multipurpose Grease <sup>1</sup>
7	Reach Cylinder Pivot Pins <sup>6</sup>					
	Rod Ends		L		2 Lube Fittings	Multipurpose Grease <sup>1</sup>
	Tube Ends		L		2 Lube Fittings	Multipurpose Grease <sup>1</sup>
23	Tilt Cylinder <sup>6, 7</sup>		L		2 Lube Fittings	Multipurpose Grease <sup>1</sup>
3	Reach Arms <sup>6</sup>		L		6 Lube Fittings	Multipurpose Grease <sup>1</sup>
5	Upper and Lower Sideshift Wear Pads		X		Check Condition, Clean and Lubricate	Multipurpose Grease <sup>1</sup>
	Hang-on SS		L		3 Lube Fittings	
	Integral SS <sup>6</sup>		L		4 Lube Fittings	
9	Load Wheel Bearings					
	Single		L		2 Lube Fittings	Multipurpose Grease <sup>1</sup>
	Tandem		L		4 Lube Fittings	Multipurpose Grease <sup>1</sup>
				L <sup>7</sup>	Clean and Repack	Multipurpose Grease <sup>1</sup>
2	Hose Sheaves and Wire Sheaves		L		Check Condition Clean and Lubricate	SAE 20W or 30W Motor Oil
14	Drive Tire Wheel Bolt Torque		X		Tighten if Required	200 N•m (148 lbf ft)
13	Drive Unit Gear Oil (Carraro)		X	C	1.75 liter (1.85 qt)	SAE 80W-90 EP Gear Oil
13	Drive Unit Gear Oil (Kordel)		X <sup>8</sup>	C	1.8 liter (1.9 qt)	SAE 80W-90
<sup>1</sup> Multipurpose #2 grease with 2 to 4% molybdenum disulfide for normal operations. <sup>2</sup> Chain Scale-Hyster-0871796 <sup>3</sup> Equalization Charge approximately each month but not more than each week. <sup>4</sup> Visual check for damage and proper adjustment. <sup>5</sup> ISO 46 or Equivalent <sup>6</sup> W20/30RA ONLY <sup>7</sup> W25/30/40ZC ONLY <sup>8</sup> Replace after first 200 hours. Check/Replace every 2000 hours or yearly.						
X=Check C=Change L=Lubricate						

## Maintenance Procedures Every 8 Hours or Daily

### WARNING

DO NOT operate a lift truck that needs repairs. If a repair is necessary, put a DO NOT OPERATE tag in the operator's area. Remove the key from the key switch.

Disconnect the battery connector before removing the MDU cover. Personal injury or equipment and tool damage can occur if the battery is not disconnected.

The capacitor in the traction motor controller can hold an electrical charge after the battery is disconnected. To prevent electrical shock and injury, discharge the capacitor before inspecting or repairing any component. Wear safety glasses. Make certain the battery has been disconnected. Discharge the capacitors in the controller by connecting a load (such as a 200-ohm, 2-watt resistor) across the controller's B+ and B- terminals. DO NOT use a screwdriver to discharge the traction motor controller. See Figure 9.

Inspect the lift truck every 8 hours or daily before use. Put the lift truck on a level surface. Lower the carriage and forks, and turn the key switch to the OFF position.

### CHECKS BEFORE OPERATION

Make the following checks:

- Safety labels in place and legible
- Battery electrolyte level
- Make sure the battery is clean and is the correct size and weight for the lift truck
- Condition of the wheels and tires
- Condition of the forks, carriage, and mast
- Oil level in the hydraulic reservoir
- Leaks in the hydraulic system

If repair is required, DO NOT operate a lift truck until the problems are corrected.

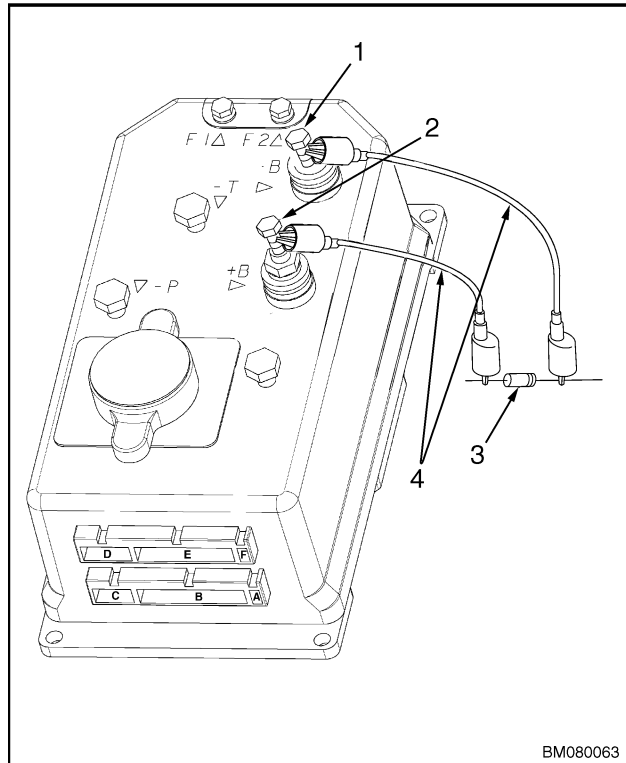

1. NEGATIVE CONNECTION
2. POSITIVE CONNECTION
3. 200-OHM, 2-WATT RESISTOR
4. INSULATED JUMPER WIRES

*Figure 9. Discharging Controller*

### HOW TO MAKE CHECKS WITH KEY SWITCH OFF

#### Safety Labels

### WARNING

If labels that have warnings or instructions are damaged, they must be replaced immediately.

**Check that all safety labels are installed in the correct locations on the lift truck. Make sure that all labels are not damaged and that they can be read. If necessary, see the PARTS MANUAL for your lift truck for the correct location of the labels.**

Safety labels are installed on the lift truck to give information about possible hazards. It is important that all safety labels are installed on the lift truck and can be read. If labels are missing or damaged, replace. See the Parts Manual for label replacement for your lift truck.

Put the lift truck on a level surface. Lower the forks and turn the key switch to the OFF position. Disconnect the battery. Open the drive unit compartment cover. On the W25/30/40ZC, also open the hydraulic compartment cover located in the front of the truck. Check for leaks and conditions that are not normal. Clean any oil leaks or spills. Make sure that lint, dust, paper, and other materials are removed from the compartment(s).

### Battery



#### **WARNING**

**DO NOT lay tools on top of the battery.**

**DO NOT put hands, arms, feet, or legs between the battery and a solid object. Batteries are very heavy and can cause an injury.**

**The acid in the electrolyte can cause injury. If the electrolyte is spilled, use water to flush the area. Make the acid neutral with a solution of sodium bicarbonate (baking soda). Acid in the eyes must be immediately flushed with water continuously for fifteen minutes, then seek medical attention.**

**Batteries generate explosive fumes. Keep the vents in the caps clean. Keep sparks or open flames away from the battery area. DO NOT make a spark from the battery connections. Disconnect the battery when performing maintenance.**

Check for loose or broken electrical connections and damaged wires or cables. Examine the battery case for damage and leakage. See the battery dealer in the area to repair any damage to the battery or cables.

Check that the vent caps are clear. Check the electrolyte level daily on a minimum of one cell. If one cell is low, check the rest of the cells. Check the level when the electrolyte has stabilized. Check the electrolyte level on all cells every week. Fill to the correct level. The correct level is generally halfway between the top of the plates and the bottom of the fill hole. Refer to the battery manufacturer's recommendations. Add only distilled water.

Check the battery case, connector, and cables for damage, cracks, or breaks. See the battery dealer in your area to repair any damage. Keep the battery case and the battery compartment clean and painted. Leaks and corrosion from the battery can cause a malfunction in the electric controls of the lift truck. Use a water and soda solution to clean the battery and the battery compartment. Keep the top of the battery clean, dry, and free of corrosion.

Make sure the battery is the correct weight and size. Prevent side-to-side movement of the battery by adjusting the brackets on either side of the battery. See the section Capacities and Specifications 8000SRM1028. The proper battery specifications are provided in Battery Maintenance in this section and in the Operating Manual. The Operating Manual is located in the container on the drive unit cover. This is a permanent reference and must be available for use at all times.

## Brake

Fully raising or lowering the control handle will apply an electrical brake that is mounted on the drive motor. See Figure 10. When the brake is applied, a switch disconnects the power to the traction circuit. When the control handle is released from the operating position, it will automatically return to the vertical position and apply the brake.

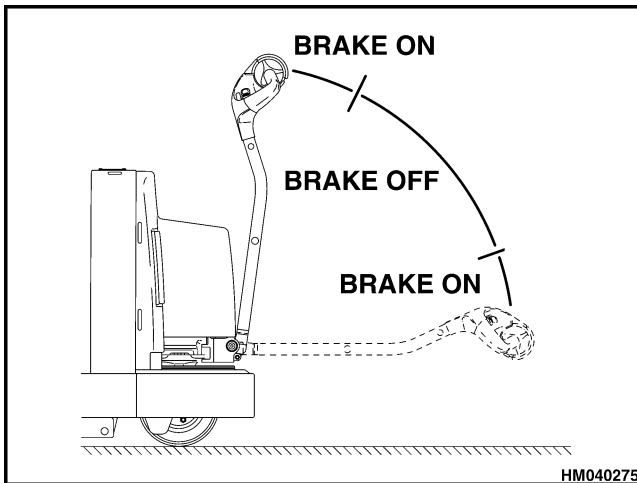

Figure 10. Brake Operation

## Tires and Wheels



### CAUTION

If the drive wheel has been removed and installed, check all wheel bolts after 2 to 5 hours of operation. Tighten the bolts in a cross pattern as shown in Figure 15. Tighten the bolts to the value shown in the Maintenance Schedule. When the bolts stay tight after 8 hours, the interval for checking the torque can be extended to 350 hours.

Inspect the drive tire and load wheels for damage. Inspect the tread and remove any objects that will cause damage. See Figure 11. Inspect the wheels for loose or missing parts. Remove any wire, strapping, or other material wound around the axles.

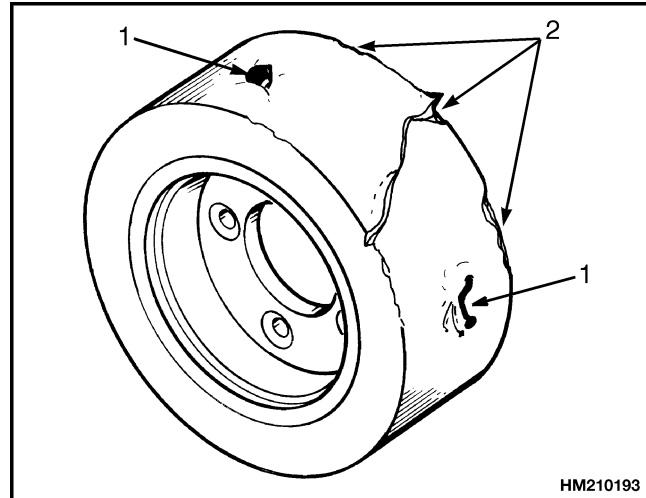

1. REMOVE NAILS, GLASS, AND METAL
2. MAKE EDGES SMOOTH

Figure 11. Tire and Wheels Inspection

## Mast, Forks, and Lift Chains



### WARNING

When working on or near the mast or carriage, see Safety Procedures When Working Near Mast.

**DO NOT** try to correct fork tip alignment by bending the forks or adding shims. Never repair damaged forks by heating or welding. Forks are made of special steel using special procedures. Replace damaged forks.

Adjust the forks as far apart as possible for maximum support of the load. Hook forks are connected to the carriage by hooks and lock pins. These lock pins are installed through the top fork hooks and fit into slots in the top carriage bar. Raise the lock pin in each fork to slide the fork on the carriage bar. See Figure 12.

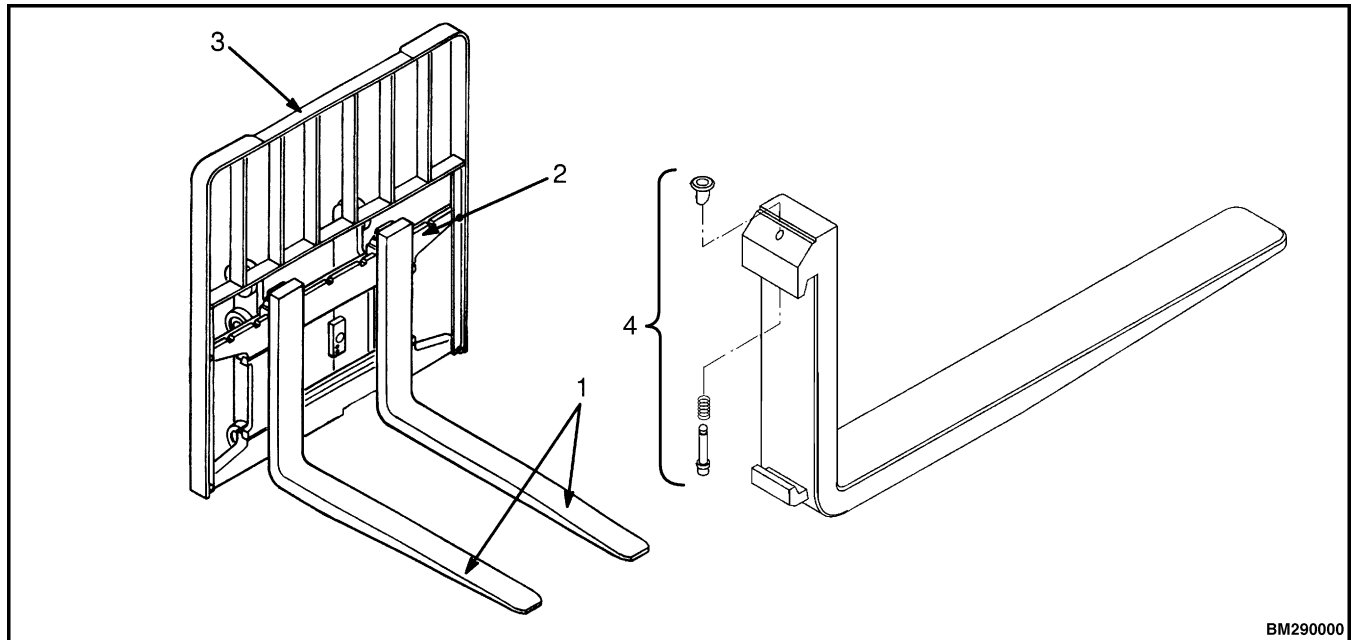

BM290000

- |  |   |
|--|---|
| <ol style="list-style-type: none"> <li>1. FORK</li> <li>2. CARRIAGE</li> </ol> | <ol style="list-style-type: none"> <li>3. LOAD BACKREST</li> <li>4. LOCK PIN</li> </ol> |
|--|---|

**Figure 12. Hook-Type Fork**

1. Inspect the welds on the mast and carriage for cracks. Make sure the nuts and capscrews are tight.
2. Inspect the mast header hoses and fittings for hydraulic leaks. Check the hose cover for cracks or exposed reinforcement. Check for broken or defective clamping devices. Repair or replace any damaged components as necessary.
3. Inspect the channel for excessive wear in the areas of roller contact. Check the rollers for wear or damage.
4. Inspect the load backrest extension for cracks and damage.
5. Inspect the forks for cracks and wear. See Figure 13. Check that the fork tips are aligned within 3% of each fork length [32.00 mm (1.26 in.) for a standard 1067 mm (42 in.) fork]. Some applications can require closer alignment. Check that the bottom of the fork is not worn. Check that the thickness of the fork blade (5, Figure 13) is at least 90% of the thickness of the fork shank (DIMENSION X). The fork's thickness can also be checked using fork tool 3020387.



### WARNING

Always wear the proper protective equipment including eye protection and petroleum-resistant gloves when handling hydraulic oil. Thoroughly wash oil from exposed areas of skin as soon as possible.

Never check for leaks by putting hands on hydraulic lines or components under pressure. Hydraulic oil under pressure can be injected into the skin.

Completely lower forks to relieve hydraulic pressure before disassembling any part of the lift pump or disconnecting any hydraulic hoses.

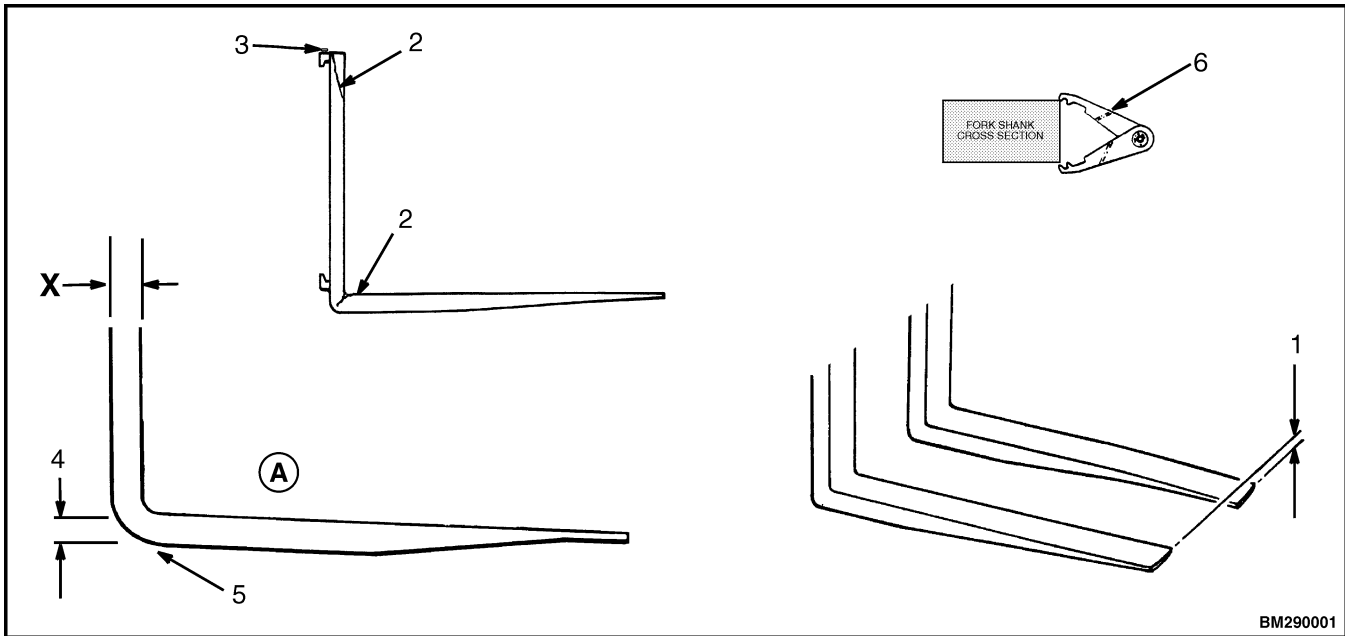

Fork Tip Alignment	
Length of Forks	3% Dimension
0914 mm (36 in.)	27.00 mm (1.10 in.)
1067 mm (42 in.)	32.00 mm (1.26 in.)
1220 mm (48 in.)	37.00 mm (1.46 in.)
1371 mm (54 in.)	40.00 mm (1.57 in.)
1524 mm (60 in.)	46.00 mm (1.81 in.)

- |   |   |
|---|---|
| <ol style="list-style-type: none"> <li>1. TIP ALIGNMENT (MUST BE WITHIN 3% OF FORK LENGTH)</li> <li>2. CRACKS</li> <li>3. LATCH DAMAGE</li> </ol> | <ol style="list-style-type: none"> <li>4. THICKNESS OF BOTTOM OF FORK (MUST BE 90% OF DIMENSION X)</li> <li>5. FORK BLADE (BOTTOM OF FORK)</li> <li>6. FORK TOOL 3020387</li> </ol> |
|---|---|

**Figure 13. Check the Forks**

- |   |  |
|---|--|
| <ol style="list-style-type: none"> <li>6. Check for any damaged or broken parts that are used to keep the forks locked in position.</li> <li>7. If the lift truck is equipped with a sideshift carriage or attachment, inspect the parts for cracks and wear.</li> <li>8. Check that the lift chains are correctly lubricated.</li> <li>9. Inspect the lift chains for cracks or broken links and pins.</li> <li>10. Inspect the chain anchors and pins for cracks and damage.</li> </ol> | <ol style="list-style-type: none"> <li>11. Make sure the lift chains are adjusted so they have equal tension. If the chains need to be replaced or adjusted, service must be performed by authorized personnel.</li> </ol> |
|---|--|

**Reach Mechanism (W20/30ZR)**



**WARNING**

**Make sure the key switch is in the OFF position and the key is removed from the switch before doing this check.**

1. Check for cracks at the welds on the reach frames and scissor arms.



2. Check the frame channel for excessive wear in the areas of roller contact. Check the rollers for wear or damage.
3. Check the load backrest extension for cracks and damage. Make sure the nuts and bolts for the load backrest extension are tight.

### Control Handle

Check that the steering operates smoothly and gives good steering control. Move the control handle to the operating position and move the handle to the left or right to steer the lift truck.

### Hydraulic System



#### WARNING

Always wear the proper protective equipment including eye protection and petroleum-resistant gloves when handling hydraulic oil. Thoroughly wash oil from exposed skin as soon as possible.

Completely lower forks to relieve hydraulic pressure before disassembling any part of the lift pump or disconnecting any hydraulic hoses.

The hydraulic oil is hot at normal operating temperatures. Be careful when draining the oil.

Never check for leaks by putting hands on hydraulic lines or components under pressure. Hydraulic oil under pressure can be injected into the skin.



#### CAUTION

Protect the hydraulic system from dirt and contaminants when servicing the hydraulic system.

Never operate the pump without the proper amount of oil in the hydraulic system. The operation of the hydraulic pump with low oil levels will damage the pump.

Inspect all hydraulic hoses and fittings for leaks. Check for broken or defective clamping devices. Repair or replace any damaged components as necessary.

If leaks are evident in the hydraulic system, repair the leaks and check the fluid level. Use the oil specified in the Maintenance Schedule.

Oil fill level is shown on outside of translucent reservoir. Check the hydraulic oil level when the oil is at room temperature and mast is in the lowered position. The hydraulic oil level should be up to the 11L mark on the W30/40ZA and W20/30-ZR, or up to the MINI mark on the W25/30/40ZC. Check the level while filling. **DO NOT OVERFILL.** Oil will leak from the breather if too full. After filling, make sure to install the breather cap properly to prevent oil leaks.

### HOW TO MAKE CHECKS WITH KEY SWITCH ON

#### Check for Leaks in Lift System



#### WARNING

Make sure the area around the lift truck is clear before moving the lift truck or checking for correct operation. Be careful when making the checks.

Never check for leaks by putting hands on hydraulic lines or components under pressure. Hydraulic oil under pressure can be injected into the skin.

Never allow any part of your body under the forks. **DO NOT** put any part of your body in or through the lift mechanism. Refer to Safety Procedures When Working Near Mast.

The capacitor in the transistor controller can hold an electrical charge after the battery has been disconnected. Avoid contact with any electrical connections when checking for leaks in the lift system.

1. Remove the drive unit compartment cover on the W30/40ZA and W20/30ZR. On the W25/30/40ZC remove the hydraulic compartment cover.
2. Visually check for leaks in the lift system. Inspect the condition of the hydraulic hoses, tubes and connections for leaks, cracks, or other obvious damage.
3. Turn the key switch to the ON position. Raise and lower the forks several times without a load. All moving components must raise and lower smoothly. The forks must lower completely. Check for leaks.